



COAST GUARD

FISHERIES AND OCEANS CANADA

VANCOUVER MARINE COMMUNICATIONS AND TRAFFIC SERVICES

PHONE: 604-666-6011 FAX: 604-666-8453

EMAIL: RMIC-PACIFIC@PAC.DFO-MPO.GC.CA

NOTICE TO SHIPPING REQUEST

Week of: October 5th, 2009

Organization name: Kiewit Flatiron General Partnership
Contact number(s): 604-629-5453
On site contact: Jeff Stoos or Oscar Cotalico
On site contact number(s): 604-818-1612 or (604)790-0053

Location the activity will take place (e.g. geographical location or Latitude and Longitude):

West of the Existing Port Mann Bridge in Construction Zone 1, Zone 2 & Zone 3.

Hours of operation and start and end times/dates (eg. 8-5, Monday to Friday/daylight hours etc):

The D.B. Bremerton, and the No. 6 derrick, along with several support barges, will be moored on the border between Zone 2 and Zone 3, west of the main tower of the existing bridge. These barges will be operating 24 hours a day, for the entire week, starting September 28th, 2009.

The RE McKenzie derrick and two support barges will be moored in Zone 1. These barges will be operating Monday through Friday between the hours of 0600 and 1800.

The Peter D derrick and a support barge will be moored in Zone 1. These barges will be operating Monday through Friday between the hours of 0600 and 1800.

The Dredge Columbia and support derricks will be located in Construction Zone 2. These barges will be operating 24 hours a day, for the entire week, starting October 5th, 2009.

Description of activity taking place and any restrictions to the waterway (eg. closing a channel etc.):

The D.B. Bremerton will be positioned at the South side of the N1 footing for collar installation. The No. 6 derrick will be positioned on the North side of the N1 footing for excavation of pile at N1. This activity will restrict maneuverability of vessel traffic in the Main Navigational Passage.

The RE McKenzie derrick and two equipment barges will be moored North of Tree Island in Construction Zone 1. These barges will be installing the construction access trestle west of the existing Port Mann Bridge, on the North of Tree Island.

The Peter D Anderson derrick and an equipment barge will be moored in Construction Zone 1, adjacent to the Essondale Channel on the north side. These barges will be installing falsework and permanent pile for Pier N5 of the New Port Mann Bridge. This activity in combination with the RE McKenzie will close the Essondale Passage for the week starting October 5th, 24 hours a day, until the end of shift on Friday, October 7th.

The Dredge Columbia will be removing sand in Construction Zone 2 for barge access. This activity will close both the North and South Working Passages. A pipeline for the dredge material will also be positioned across the Essondale Channel which will restrict maneuverability of vessel traffic in the Essondale Channel from the bridge site to the Fraser Mill site approximately 3 km downstream.

October 1, 2009

Vessels participating or support vessels such as dredges, tugs, etc.(if applicable):

Vessel Assist: Vessel Iris G

(604) 779-3789 and monitoring VHF channel 64A

D.B. Bremerton and scows, Towing Tug, Fraser River Pile & Dredge Derrick Barges and scows, Vancouver Pile Driving Derrick Barge and scow.

VHF Channel to be monitored (if applicable):

Emergency: 16

Working: 64A

Special Requests and additional information (eg. minimum wash, clearance restrictions etc):

No wake zones will be designated 200 meter upstream and downstream of all marine construction vessels.

The Essondale Channel will be marked on the Trestle with Green and Red Lateral Lighting. It will be a 4 second flash pattern consisting of a .5 sec flash with 3.5 sec eclipse.

WARNING:

There are submerged hazards located on the North side of the Peter D Anderson barge. Temporary piles have been installed around them to keep vessels away from the hazard. Please be advised to stay clear of this area so as not to damage your vessels.

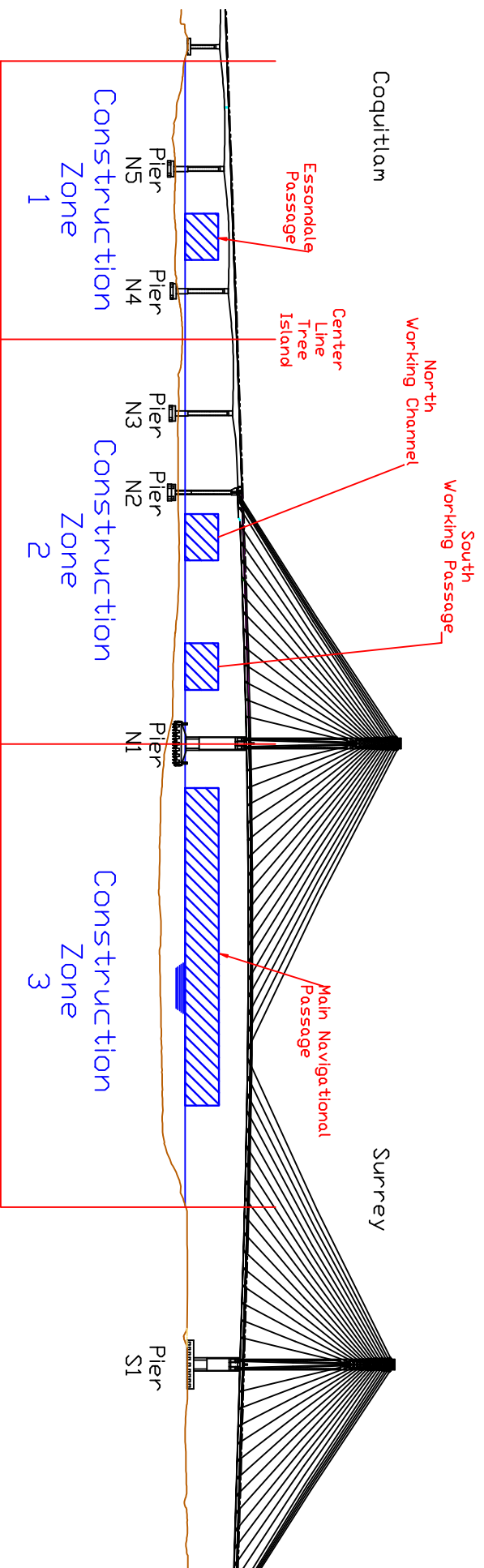

Marine Construction Update

Week Of: October 5, 2009

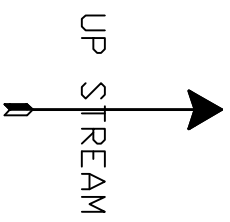

Day	Zone 1		Zone 2		Zone 3	
	Time	Activity	Time	Activity	Time	Activity
Monday	24Hr	Closed	24Hr	Closed	24Hr	RM
Tuesday	24Hr	Closed	24Hr	Closed	24Hr	RM
Wednesday	24Hr	Closed	24Hr	Closed	24Hr	RM
Thursday	24Hr	Closed	24Hr	Closed	24Hr	RM
Friday	24Hr	Closed	24Hr	Closed	24Hr	RM
Saturday	24Hr	Open	24Hr	Closed	24Hr	RM
Sunday	24Hr	Open	24Hr	Closed	24Hr	RM

- Open: Channel is Open to all traffic
- Closed: Channel is Closed for the time stated
- RM: Channel is open with Restricted Maneuverability due to construction activities

